

# 2/4 SERIES COUPLINGS

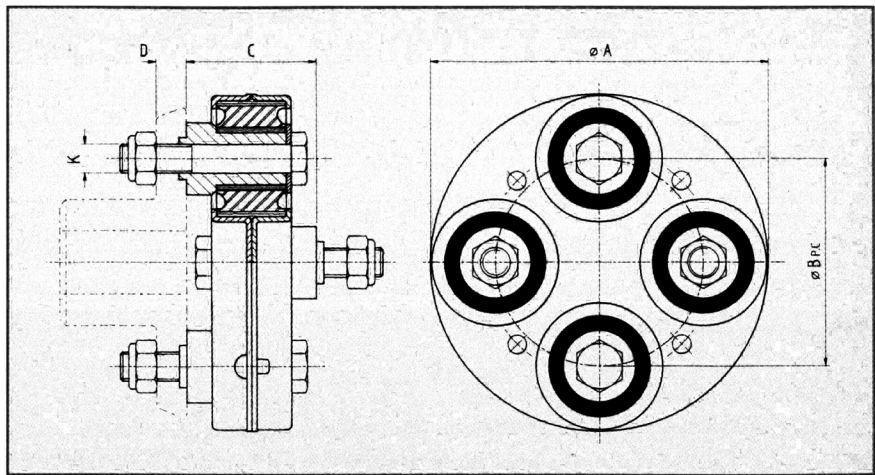

Block Type	Maximum Torque Nm	* Normal Torque Nm	** Maximum Vibratory Torque $\pm$ Nm	DYNAMIC TORSIONAL STIFFNESS MNm/RAD					† Static Axial Stiffness N/mm	† Static Radial Stiffness N/mm	† Dynamic Conical Stiffness Nm/deg	Inertia kg.m <sup>2</sup>
				NATURAL RUBBER				NEOPRENE 60/65				
				50/55	60/65	70/75	75/80					
40	147	49	24.5	.0012	.0020	.0035	.004	0.0028	196	1472	4	.0008
50	235	78	39.2	.0009	.0015	.0026	.003	0.0021	177	687	6	.0019
60+	392	131	65.3	.0024	.0040	.0070	.008	0.0056	265	1177	10	.0051
65	598	199	100	.0036	.0060	.0105	.012	0.0084	314	1560	16	.0072
70	735	245	122	.0048	.0080	.0140	.016	0.0112	314	1765	21	.0116
70+	929	310	155	.0080	.0130	.0220	.025	0.0180	350	2804	25	.0116
80	1080	360	180	.0072	.0120	.0210	.024	0.0168	402	1962	30	.0207
80+	1351	450	22.5	.0090	.0140	.0250	.029	0.0200	491	2453	43	.0207
90	1492	497	249	.0102	.0170	.0297	.034	0.0238	470	2256	47	.0374
100	1898	633	316	.0108	.0180	.0315	.036	0.0252	422	2060	48	.0600
105	2712	904	452	.0102	.0170	.0297	.034	0.0236	705	1962	77	.0883
120	3254	1085	542	.0156	0.260	.0455	.052	0.0364	705	1962	101	.0517

\*Normal torque based on a service factor of 3. \*\*Maximum vibratory torque base frequency of 450 vpm.  
 †All stiffness values are for natural rubber 60°/65° duro.

Block Type	Maximum Coupling Angles		Maximum Extension or Compression per Coupling with $\theta_1^\circ$ and $\theta_2^\circ$ (mm)		Maximum Radial Mis-alignment of Single Couplings (mm)	†† Maximum Speed of Single Couplings rev/min	DIMENSIONS (mm)					Basic Coupling Assembly Number	Fixing Kit Number	Weight kg
	Continuous $\theta_1^\circ$	Momentary $\theta_2^\circ$	$\theta_1^\circ$	$\theta_2^\circ$			A	B	C	D	K			
40	2°	5°	1.2	3.2	0.3	6000	102	65.08	41.5	10	M10	LA21001	LA22001	0.6
50*	3.5°	8°	1.6	4.0	0.3	5000	128	80.96	47.5	10	M12	LA21002	LA22002	1.0
60+	3.5°	8°	2.4	6.4	0.4	5000	153	96.84	57.0	10	M12	LA21004	LA22004	1.7
65	3.5°	8°	2.4	6.4	0.4	5000	167	104.78	57.0	12.5	M12	LA21005	LA22005	2.3
70	3.5°	8°	2.4	6.4	0.4	5000	178	109.54	68.5	16	M16	LA21006	LA22007	3.1
70+	3.5°	8°	2.4	3.2	0.4	5000	178	109.54	68.5	16	M16	LA21008	LA22009	3.1
80	3.5°	8°	3.2	7.9	0.5	4500	203	125.42	68.5	16	M16	LA21010	LA22010	4.2
80+	3.5°	8°	3.2	3.9	0.5	4500	203	125.42	68.5	16	M16	LA21011	LA22010	4.2
90	3.5°	8°	3.2	7.9	0.5	4000	229	141.28	76.0	19	M16	LA21012	LA22012	5.9
100	3.5°	8°	3.2	7.9	0.6	3500	254	157.12	79.5	19	M20	LA21013	LA22013	7.5
105	3.5°	8°	4.0	9.5	0.6	2500	270	157.12	92.0	25	M24	LA21014	LA22014	11.3
120	3.5°	8°	4.0	9.5	0.6	2000	305	187.32	92.0	25	M24	LA21015	LA22015	13.6

††For speeds in excess of specified values or maximum shaft speeds, please consult our Engineering Department.

\*Type 50 has a ø22 hole through the centre.